

### Features

- Leading trench technology for low  $R_{DS(on)}$
- Low Gate Charge

### Product Summary

$V_{DS}$	$R_{DS(on)}$ MAX	$I_D$ MAX
-20V	45m $\Omega$ @-4.5V	-5A
	65m $\Omega$ @-2.5V	

### Application

- Video monitor
- Power management

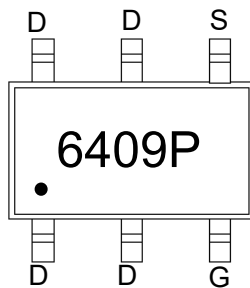

6409P: Device code

Marking and pin assignment

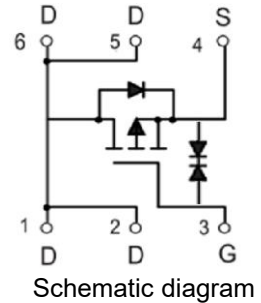
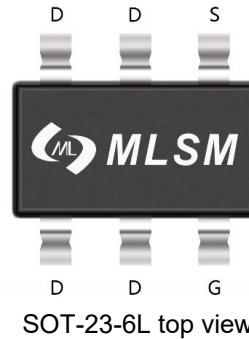

Halogen-Free

### Absolute Maximum Ratings (TA=25°C unless otherwise noted)

Symbol	Parameter	Rating	Unit
<b>Common Ratings (TC=25°C Unless Otherwise Noted)</b>			
$V_{DS}$	Drain-Source Breakdown Voltage	-20	V
$V_{GS}$	Gate-Source Voltage	$\pm 12$	V
$T_J$	Maximum Junction Temperature	150	°C
$T_{STG}$	Storage Temperature Range	-55 to 150	°C
$I_S$	Diode Continuous Forward Current	$T_c=25^\circ\text{C}$ -5	A
<b>Mounted on Large Heat Sink</b>			
$I_{DM}$	Pulse Drain Current Tested	$T_c=25^\circ\text{C}$ -30	A
$I_D$	Continuous Drain Current	$T_c=25^\circ\text{C}$ -5	A
$P_D$	Maximum Power Dissipation	$T_c=25^\circ\text{C}$ 1.5	W
$R_{\theta JA}$	Thermal Resistance Junction-to-Ambient	135	°C/W

### Ordering Information (Example)

Type	Package	Marking	Minimum Package(pcs)	Inner Box Quantity(pcs)	Outer Carton Quantity(pcs)	Delivery Mode
MLSL6409P	SOT-23-6L	6409P	3,000	45,000	180,000	7"reel

Electrical Characteristics (T <sub>J</sub> =25°C unless otherwise noted)						
Symbol	Parameter	Condition	Min	Typ	Max	Unit
Static Electrical Characteristics @ T <sub>J</sub> = 25°C (unless otherwise stated)						
BV <sub>(BR)DSS</sub>	Drain-Source Breakdown Voltage	V <sub>GS</sub> =0V, I <sub>D</sub> =-250μA	-20	--	--	V
I <sub>DSS</sub>	Zero Gate Voltage Drain Current	V <sub>DS</sub> =-20V, V <sub>GS</sub> =0V	--	--	-1	μA
I <sub>GSS</sub>	Gate-Body Leakage Current	V <sub>GS</sub> =±12V, V <sub>DS</sub> =0V	--	--	±20	μA
V <sub>GS(th)</sub>	Gate Threshold Voltage	V <sub>DS</sub> =V <sub>GS</sub> , I <sub>D</sub> =-250μA	-0.4	-0.7	-1.0	V
R <sub>DS(on)</sub>	Drain-Source On-State Resistance	V <sub>GS</sub> =-4.5V, I <sub>D</sub> =-5A	--	37	45	mΩ
		V <sub>GS</sub> =-2.5V, I <sub>D</sub> =-4A	--	50	65	mΩ
Dynamic Electrical Characteristics @ T <sub>J</sub> = 25°C (unless otherwise stated)						
C <sub>ISS</sub>	Input Capacitance	V <sub>DS</sub> =-10V, V <sub>GS</sub> =0V, f=1MHz	--	750	--	pF
C <sub>OSS</sub>	Output Capacitance		--	115	--	pF
C <sub>RSS</sub>	Reverse Transfer Capacitance		--	77	--	pF
Switching Characteristics						
Q <sub>g</sub>	Total Gate Charge	V <sub>DS</sub> =-10V, I <sub>D</sub> =-5A, V <sub>GS</sub> =-4.5V	--	9.5	--	nC
Q <sub>gs</sub>	Gate Source Charge		--	1.1	--	nC
Q <sub>gd</sub>	Gate Drain Charge		--	2	--	nC
t <sub>d(on)</sub>	Turn-on Delay Time	V <sub>DS</sub> =-10V, R <sub>L</sub> =2.5Ω, V <sub>GS</sub> =-4.5V, R <sub>G</sub> =2.8Ω	--	12.8	--	nS
t <sub>r</sub>	Turn-on Rise Time		--	8.9	--	nS
t <sub>d(off)</sub>	Turn-Off Delay Time		--	18.8	--	nS
t <sub>f</sub>	Turn-Off Fall Time		--	30	--	nS
Source- Drain Diode Characteristics						
V <sub>SD</sub>	Forward on voltage	T <sub>J</sub> =25°C, I <sub>S</sub> =-5A	--	--	-1.2	V

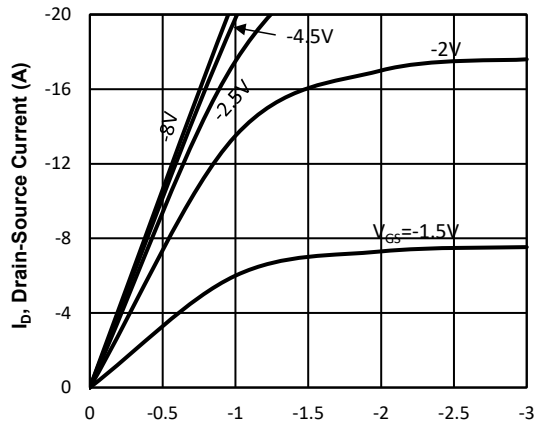
**Typical Operating Characteristics**

$V_{DS}$ , Drain-Source Voltage (V)  
**Fig1. Typical Output Characteristics**

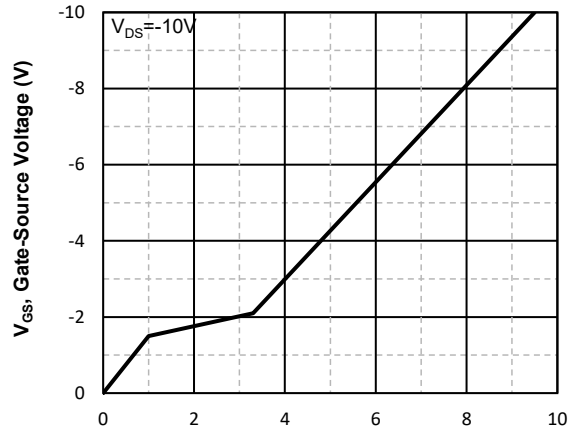

$Q_g$  -Total Gate Charge (nC)  
**Fig2. Typical Gate Charge Vs. Gate-Source Voltage**

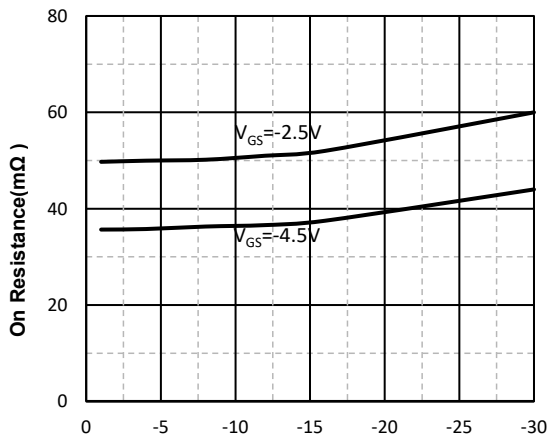

$I_D$ , Drain-Source Current (A)  
**Fig3. On Resistance Vs. Drain-Source Current**

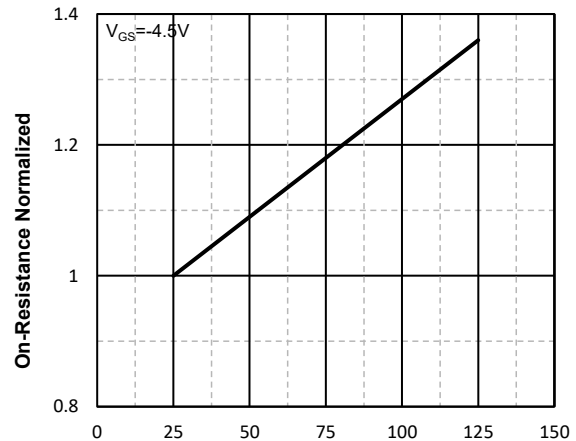

$T_j$  - Junction Temperature ( $^{\circ}C$ )  
**Fig4. Normalized On-Resistance Vs. Temperature**

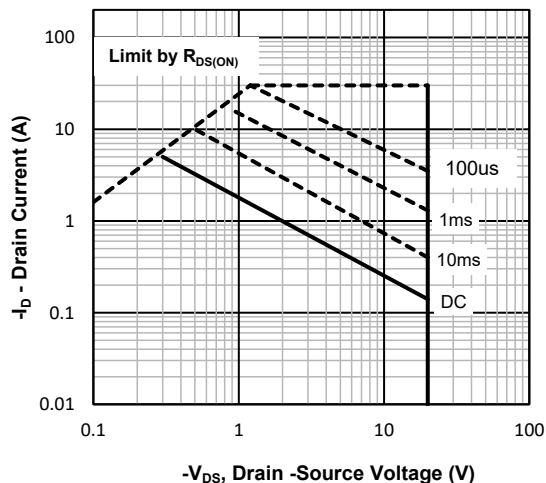

$V_{DS}$ , Drain-Source Voltage (V)  
**Fig5. Maximum Safe Operating Area**

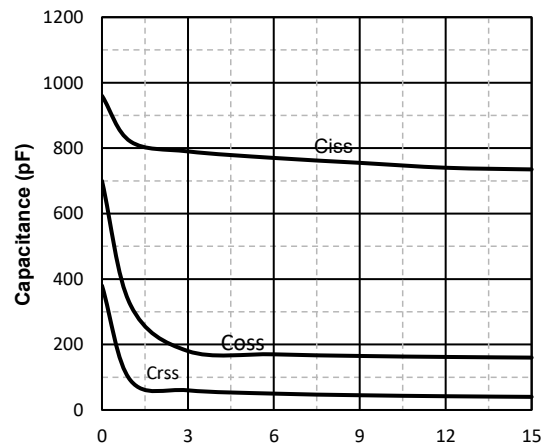

$V_{DS}$ , Drain-Source Voltage (V)  
**Fig6 Typical Capacitance Vs. Drain-Source Voltage**

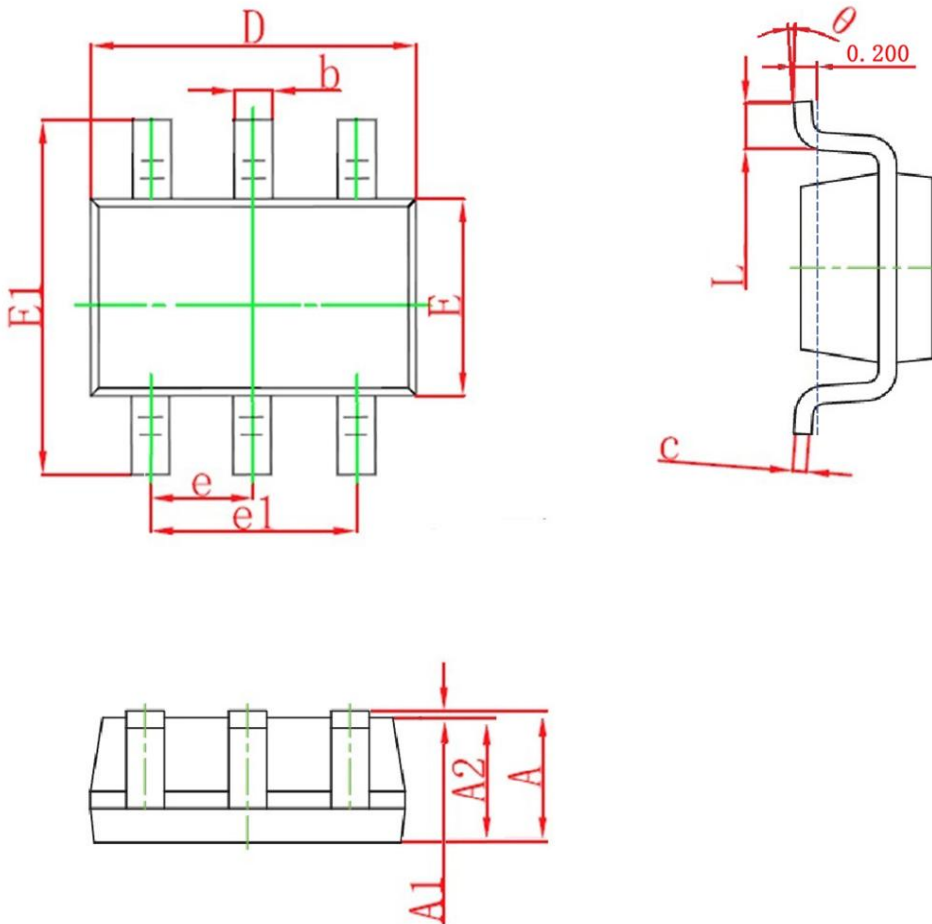
**SOT-23-6L Package information**

Symbol	Dimensions in Millimeters(mm)		Dimensions In Inches	
	Min	Max	Min	Max
A	1.050	1.250	0.041	0.049
A1	0.000	0.100	0.000	0.004
A2	1.000	1.200	0.039	0.047
b	0.300	0.500	0.012	0.020
c	0.100	0.200	0.004	0.008
D	2.820	3.020	0.111	0.119
E	1.500	1.700	0.059	0.067
E1	2.600	3.000	0.102	0.118
e	0.950TYP		0.037TYP	
e1	1.800	2.000	0.071	0.079
L	0.300	0.600	0.012	0.024
K	0°	8°	0°	8°