

Features

- Trench Power LV MOSFET technology
- High density cell design for Low $R_{DS(ON)}$
- High Speed switching

Product Summary

V_{DS}	$R_{DS(ON)}$ TYP	I_D
-30V	39mΩ@-10V	-5A
	45mΩ@-4.5V	

Application

- Battery protection
- Load switch
- Power management

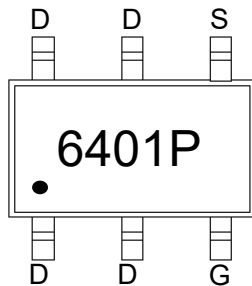

6401P: Device code

Marking and pin assignment

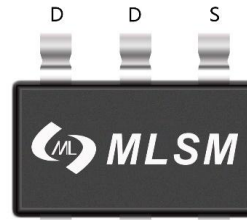

SOT-23-6L top view

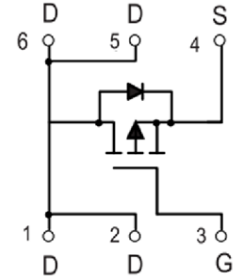

Schematic diagram



Pb-Free



Halogen-Free

Absolute Maximum Ratings (TA=25°C unless otherwise noted)

Symbol	Parameter	Rating	Unit
--------	-----------	--------	------

Common Ratings (TC=25°C Unless Otherwise Noted)

V_{DS}	Drain-Source Breakdown Voltage	-30	V
V_{GS}	Gate-Source Voltage	±12	V
T_J	Maximum Junction Temperature	150	°C
T_{STG}	Storage Temperature Range	-50 to 155	°C
I_S	Diode Continuous Forward Current	Tc=25°C -5	A

Mounted on Large Heat Sink

I_{DM}	Pulse Drain Current Tested	Tc=25°C -20	A
I_D	Continuous Drain Current	Tc=25°C -5	A
P_D	Maximum Power Dissipation	Tc=25°C 1.7	W
$R_{\theta JA}$	Thermal Resistance Junction-Ambient	135	°C/W

Ordering Information (Example)

Type	Package	Marking	Minimum Package(pcs)	Inner Box Quantity(pcs)	Outer Carton Quantity(pcs)	Delivery Mode
MLSL6401P	SOT-23-6L	6401P	3,000	45,000	180,000	7"reel

Electrical Characteristics (T _J =25°C unless otherwise noted)						
Symbol	Parameter	Condition	Min	Typ	Max	Unit
Static Electrical Characteristics @ T_J = 25°C (unless otherwise stated)						
BV _{(BR)DSS}	Drain-Source Breakdown Voltage	V _{GS} =0V, I _D =-250μA	-30	--	--	V
I _{DSS}	Zero Gate Voltage Drain Current	V _{DS} =-30V, V _{GS} =0V	--	--	-1	μA
I _{GSS}	Gate-Body Leakage Current	V _{GS} =±12V, V _{DS} =0V	--	--	±100	nA
V _{GS(th)}	Gate Threshold Voltage	V _{DS} =V _{GS} , I _D =-250μA	-0.5	-0.9	-1.3	V
R _{DS(on)}	Drain-Source On-State Resistance	V _{GS} =-10V, I _D =-5A	--	39	47	mΩ
		V _{GS} =-4.5V, I _D =-4A	--	45	64	mΩ
Dynamic Electrical Characteristics @ T_J = 25°C (unless otherwise stated)						
C _{ISS}	Input Capacitance	V _{DS} =-15V, V _{GS} =0V, f=1MHz	--	580	--	pF
C _{OSS}	Output Capacitance		--	98	--	pF
C _{RSS}	Reverse Transfer Capacitance		--	74	--	pF
Switching Characteristics						
Q _g	Total Gate Charge	V _{DS} =-15V, I _D =-5A, V _{GS} =-10V	--	6.8	--	nC
Q _{gs}	Gate Source Charge		--	1	--	nC
Q _{gd}	Gate Drain Charge		--	1.4	--	nC
t _{d(on)}	Turn-on Delay Time	V _{DS} =-15V, I _D =-5A, V _{GS} =-10V, R _G =2.5Ω	--	14	--	nS
t _r	Turn-on Rise Time		--	61	--	nS
t _{d(off)}	Turn-Off Delay Time		--	19	--	nS
t _f	Turn-Off Fall Time		--	10	--	nS
Source- Drain Diode Characteristics						
V _{SD}	Forward on voltage	T _J =25°C, I _S =-5A	--	--	-1.2	V

Typical Operating Characteristics

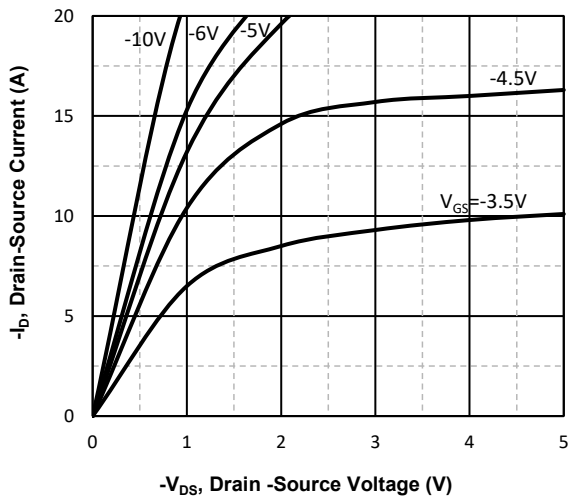

Fig1. Typical Output Characteristics

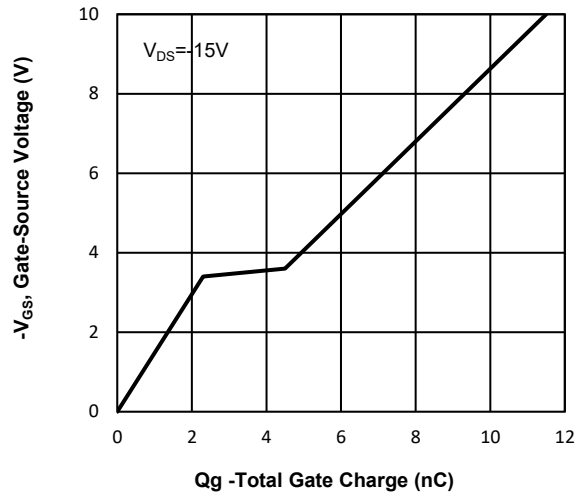

Fig2. Typical Gate Charge Vs. Gate-Source Voltage

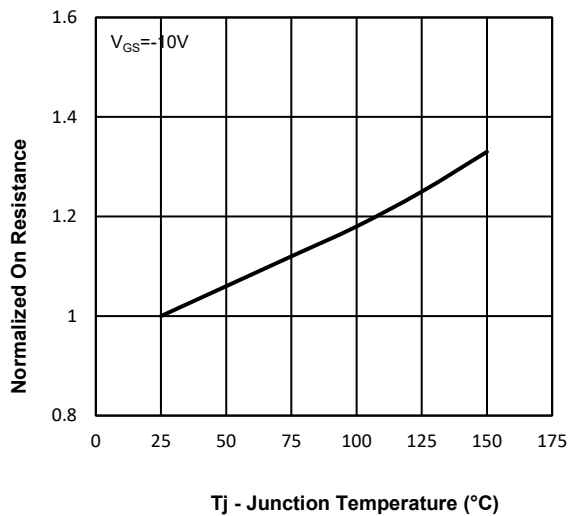

Fig3. Normalized On-Resistance Vs. Temperature

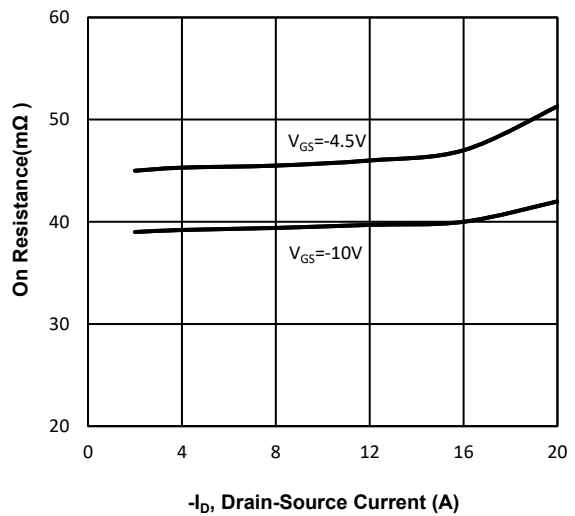

Fig4. On-Resistance Vs. Drain-Source Current

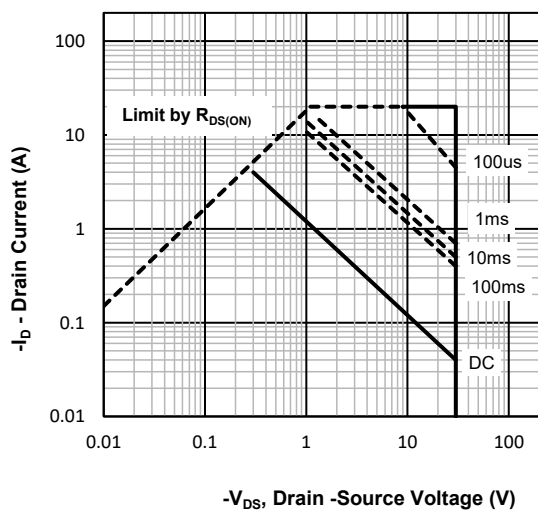

Fig5. Maximum Safe Operating Area

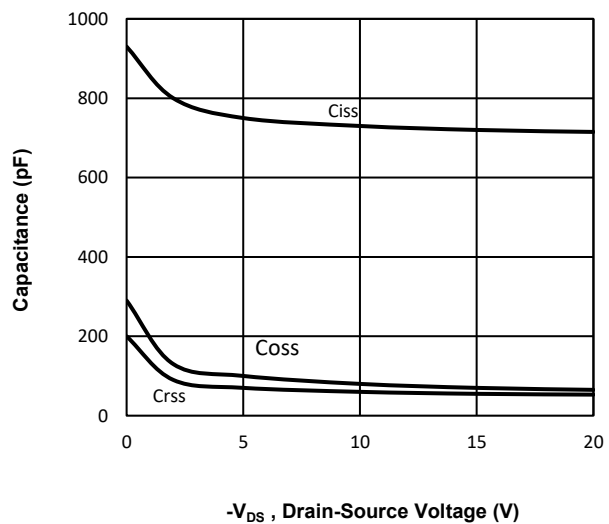
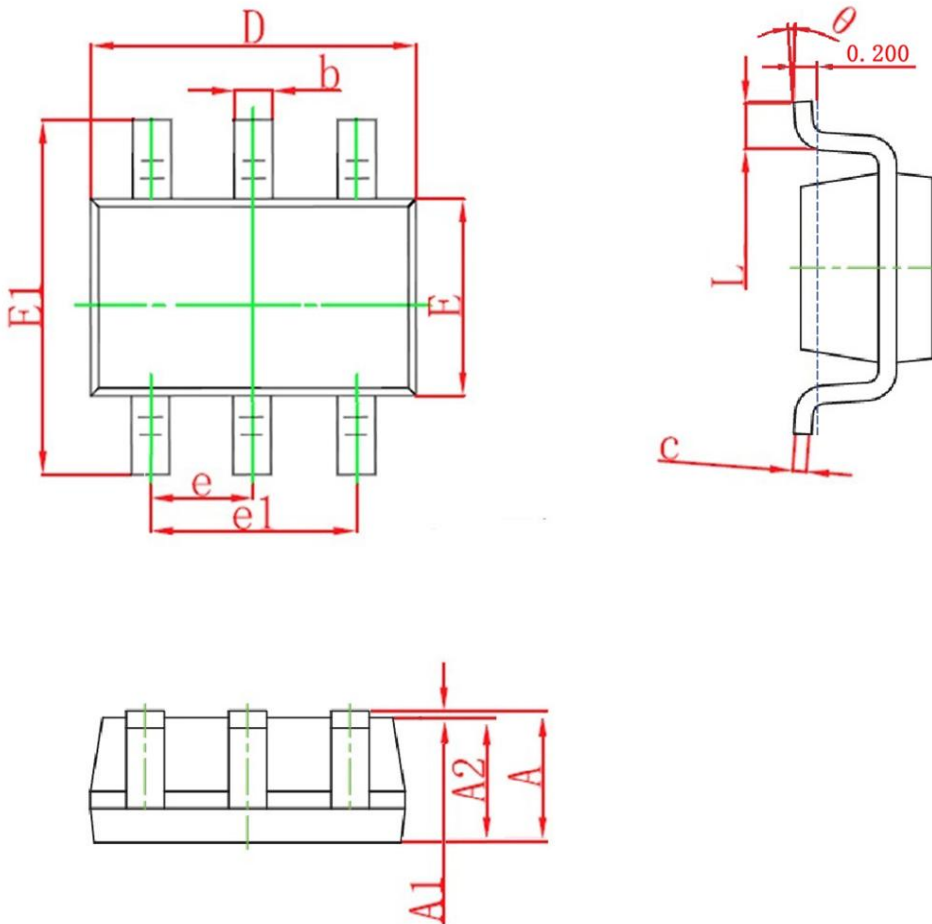

Fig6. Typical Capacitance Vs. Drain-Source Voltage

SOT-23-6L Package information

Symbol	Dimensions in Millimeters(mm)		Dimensions In Inches	
	Min	Max	Min	Max
A	1.050	1.250	0.041	0.049
A1	0.000	0.100	0.000	0.004
A2	1.000	1.200	0.039	0.047
b	0.300	0.500	0.012	0.020
c	0.100	0.200	0.004	0.008
D	2.820	3.020	0.111	0.119
E	1.500	1.700	0.059	0.067
E1	2.600	3.000	0.102	0.118
e	0.950TYP		0.037TYP	
e1	1.800	2.000	0.071	0.079
L	0.300	0.600	0.012	0.024
K	0°	8°	0°	8°